

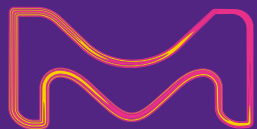

# DESIGNED BY EMBRYOLOGISTS WHO USE IT<sup>1</sup>

Gems<sup>®</sup>: A complete embryo  
medium suite, including  
the third generation  
of the world's first  
sequential media<sup>2,3</sup>



MERCK

For embryos cultured outside of the uterus, *in vivo* conditions must be recreated to stimulate embryo development.<sup>1</sup> An **optimal culture environment** is vital to support the overall performance of the ART lab and is essential to minimize stress to gametes and embryos.<sup>1-3</sup>

In the 1990s, our partner Genea (formerly Sydney IVF) developed the world's first, sequential, three-step media set.<sup>4,5</sup>



# INTRODUCING Gems<sup>®</sup>: YOUR COMPLETE RANGE OF IVF AND VITRIFICATION MEDIA

**Gems<sup>®</sup> is the third generation of this culture medium suite,<sup>4,5</sup>** developed in conjunction with Genea's in-house scientific experts. It has been conceived to support your needs at **every stage of the ART process** – from gamete analysis right through to vitrification.



**Optimised for every stage:** Gems<sup>®</sup> media include a mix of buffers\*, growth media\* and cryopreservation solutions.<sup>6</sup>



**Robust and effective media:** Unique and/or rare components to support embryo development *in vitro*.



**Long heritage:** Almost 30 year-experience in developing culture media, aiming for optimum fertility outcomes.<sup>4,5</sup>



**Established safety and efficacy:** Gems<sup>®</sup> has been in clinical use in Genea ART clinics since March 2013 helping an **estimated 6500 babies** to be born.<sup>7</sup>



**Consistently high quality batch-to-batch:** Manufactured in state of the art, medically accredited, audited facilities in Sydney (ISO13485) and extensive QA control.<sup>6</sup>



**User-friendly:** Ready-to-use solutions with clear labelling, different colors and icons aid recognition to help **minimize the potential for errors.**<sup>8</sup>

1. Testori S. HFEA Culture Media Update. 2015 [http://www.hfea.gov.uk/docs/2015-10-21\\_-\\_SCAAC\\_paper\\_-\\_Embryo\\_culture\\_media\\_update\\_-\\_ACTIVE.pdf](http://www.hfea.gov.uk/docs/2015-10-21_-_SCAAC_paper_-_Embryo_culture_media_update_-_ACTIVE.pdf) Accessed 14.04.16.  
2. Swain, Jason E. et al. "Optimizing the culture environment and embryo manipulation to help maintain embryo developmental potential." *Fertility and sterility* 105.3 (2016): 571-587.  
3. Will, Matthew A. Natalie A. Clark, and Jason E. Swain. "Biological pH buffers in IVF: help or hindrance to success." *Journal of assisted reproduction and genetics* 28.8 (2011): 711-724.  
4. QFRM190 Gems<sup>®</sup> Clinical Evaluation Report.  
5. Mortimer D. "Human blastocyst development media." *Human Reproduction* 16.12 (2001): 2725-2725.  
6. QFRM40 Gems<sup>®</sup> instructions for use.  
7. Data on file at Genea ART clinics. QRTV318\_09 Human Embryo Culture in Geri<sup>®</sup>.  
8. Human Fertilisation and Embryology Authority (HFEA). Adverse incidents in fertility clinics: lessons to learn 2010–2012. Available at <http://www.hfea.gov.uk/9449.html>. Accessed January 2017. Last updated September 2015.  
\* Buffers are pH stabilized with HEPES allowing their use outside of a CO2 regulated environment. Media are pH stabilized with HCO3 (bicarbonate) which requires CO2 to be an effective buffer.  
\*\* Across all types of IVF/ICSI patients for all ages.

# DEVELOPED BY USER FOR USERS

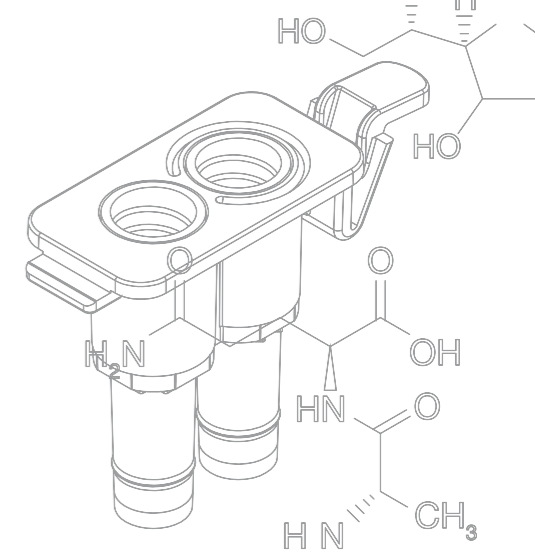
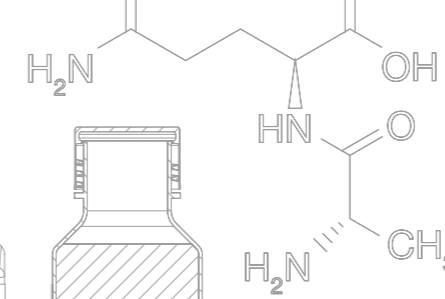
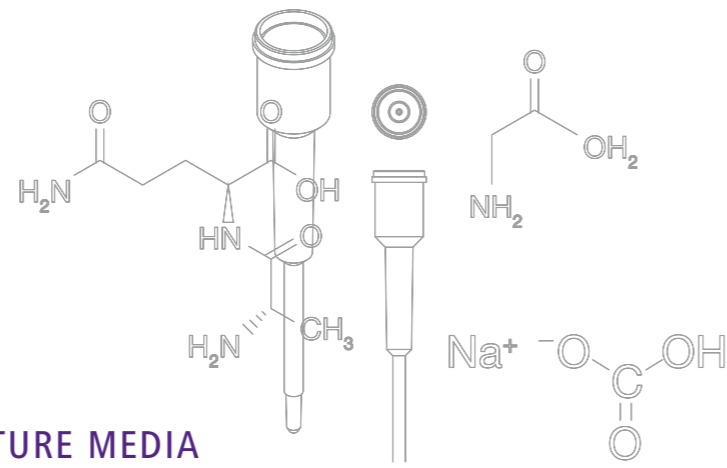

## ALMOST 30 YEARS DEVELOPING CULTURE MEDIA

Genea's embryologists and andrologists bring the expertise of decades dedicated to ART to the Gems® media suite.

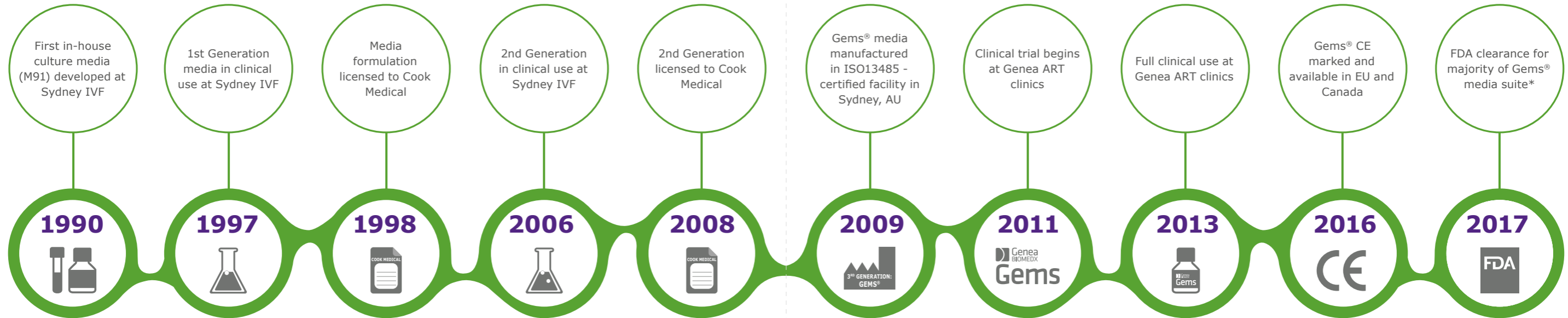

# OPTIMISED FOR EVERY STEP

Gems® adapts to your laboratory practice and workload demands with a **complete range of IVF and vitrification media and two different bottle sizes** available for most of the medium in the suite.\*

## GAMETE HANDLING AND PREPARATION



**Oocyte Retrieval Buffer<sup>1</sup>**

ORB 50	50mL
ORB-20	20mL

- Conceived to reduce stress on the oocytes during their removal from ovarian follicles.
- Supplemented with gentamycin (0.01 mg/mL).



**Sperm Wash Gradient Set<sup>3</sup>**

SWG-45P-50**	50mL
SWG-90P-50**	50mL

- Used to separate sperm from seminal plasma as well as separating highly motile sperm in preparation for insemination.
- Supplemented with human serum albumin (10mg/mL), gentamycin (0.01mg/mL) and coated silica.



**Sperm Medium<sup>2</sup>**

SPM 50	50mL
SPM-20	20mL

- Used to wash and resuspend sperm for the insemination step in IUI, IVF or in diagnostic washing, optimised for storage in a 6% CO<sub>2</sub> incubator.
- Supplemented with human serum albumin (10 mg/mL) and gentamycin (0.01 mg/mL).



**Sperm Buffer<sup>4</sup>**

SPB 50	50mL
SPB-20	20mL

- Used to wash and resuspend sperm for the insemination step in intrauterine insemination (IUI), IVF or in diagnostic washing.
- Supplemented with human serum albumin (10 mg/mL) and gentamycin (0.01 mg/mL).

1. QFRM536 Oocyte Retrieval Buffer ORB-50 and ORB-20 tech specs.  
 2. QFRM906 Sperm Medium SPM-50 and SPM-20 tech specs.  
 3. QFRM904 Sperm Wash Gradient Set SWG-01 tech specs.  
 4. QFRM903 Sperm Buffer SPB-50 and SPB-20 tech specs.  
 \* Exceptions: Sperm Wash Gradient Set are only available in 50ml. Warming Set Sol.1, Warming Set Sol.2 & Vitrification Set Sol.3 are only available in 10 ml. VitBase is only available in 20ml.  
 \*\* Not for individual sale.  
 Note: Sperm Medium and Sperm Wash Gradient Set not available in US.

## VITRIFICATION & WARMING SOLUTIONS



**Vitrification Set<sup>5</sup>**

VIT-SOL1-20*	20mL
VIT-SOL2-20*	20mL
VIT-SOL3-10*	10mL

- Cryoprotectant solutions protect against cell damage (EG/DMSO/Trehalose). For the manual vitrification of human embryos.



**Warming Set<sup>6</sup>**

WRM-SOL1-20*	20mL
WRM-SOL2-10*	10mL
WRM-SOL3-10*	10mL

- For the warming of embryos vitrified using either the Vitrification Set or the Gavi® Medium Cartridge.



**Gavi® Medium Cartridge<sup>8</sup>**  
 (Gavi® Solution 1 and Gavi® Solution 2).

GAVI-MED-20*	320 µL
--------------	--------

- Used in conjunction with the Gavi® System for the vitrification of human embryos (EG/DMSO/Trehalose).

## OTHERS



**VitBase<sup>7</sup>**

VBS-20	20mL
--------	------

- HEPES buffered medium.
- Maintains embryos for a short period of time in a non-gassed environment.

5. QFRM910 Vitrification Set VIT-01 tech specs.  
 6. QFRM911 Warming Set WRM-01 tech specs.  
 7. QFRM912 VitBase VBS-20 tech specs.  
 8. QFRM913 Gavi® Medium Cartridge Gavi®-MED-20 tech specs.  
 \* Not for individual sale.  
 EG= Ethylene glycol. DMSO= Dimethyl Sulfoxide.

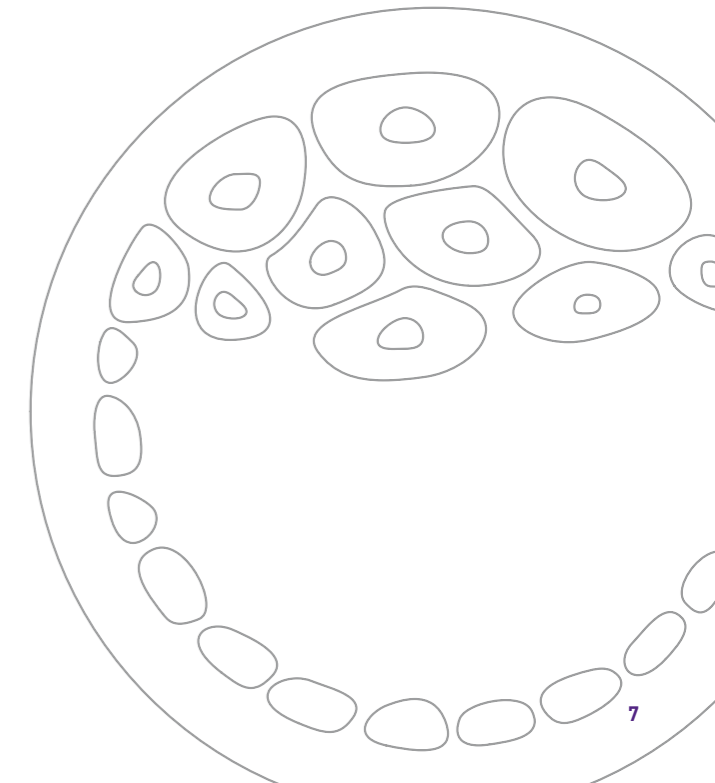

# OPTIMISED FOR EVERY STEP

## GROWTH MEDIA

Each Gems® growth medium has a **tailored composition for optimal support** that includes amino acids, vitamins, glucose and balanced salts — which are key for the normal metabolism of gametes and embryos.<sup>1</sup>

Gems® growth media are optimised for use in a low oxygen (5%) environment.<sup>2</sup>

### Fertilisation Medium

FEM-50 50mL  
FEM-20 20mL

- Used to provide a suitable environment for both oocytes and sperm, to promote optimal fertilisation rates. Supplemented with human serum albumin (5 mg/mL) and gentamicin (0.01 mg/mL)<sup>3</sup>.
- Higher concentration of glucose and lower concentration of magnesium\*.

### Cleavage Medium

CLM-50 50mL  
CLM-20 20mL

- Higher EDTA and concentration of pyruvate, lactate and non-essential amino acids, to support the embryo to reach the cleavage stage<sup>4,\*</sup>.
- Lower concentration of glucose and essential amino acids\*.

### Blastocyst Medium

BLM-50 50mL  
BLM-20 20mL

- No EDTA and lower concentration of pyruvate, lactate and non-essential amino acids\*.
- Higher concentration of glucose and essential amino acids, to support the embryo development from cleavage to the blastocyst stage<sup>5,\*</sup>.

### Geri® Medium

ONE-50 50mL  
ONE-20 20mL

**Ready-to-use solution to support extended culture** with uninterrupted incubation up to blastocyst stage<sup>6,7</sup>. Embryos retain their microenvironment for the entirety of in vitro culture.

- **Replaces cleavage and blastocyst media** with no need for supplements and no need to replace or replenish the media.<sup>7</sup>
- **Helps simplify workflow and processes** with a balance of compounds that aids in the development of the embryo from zygote to blastocyst.
- Contains Glutamine in dipeptide form, as Alanyl-Glutamine, to **reduce harmful ammonia levels**.<sup>8</sup>

Whether your lab processes involve movement of embryos on Day 3 or extended embryo culture up to blastocyst stage, with Gems® you have the flexibility to **choose your preferred culture ally**.\*

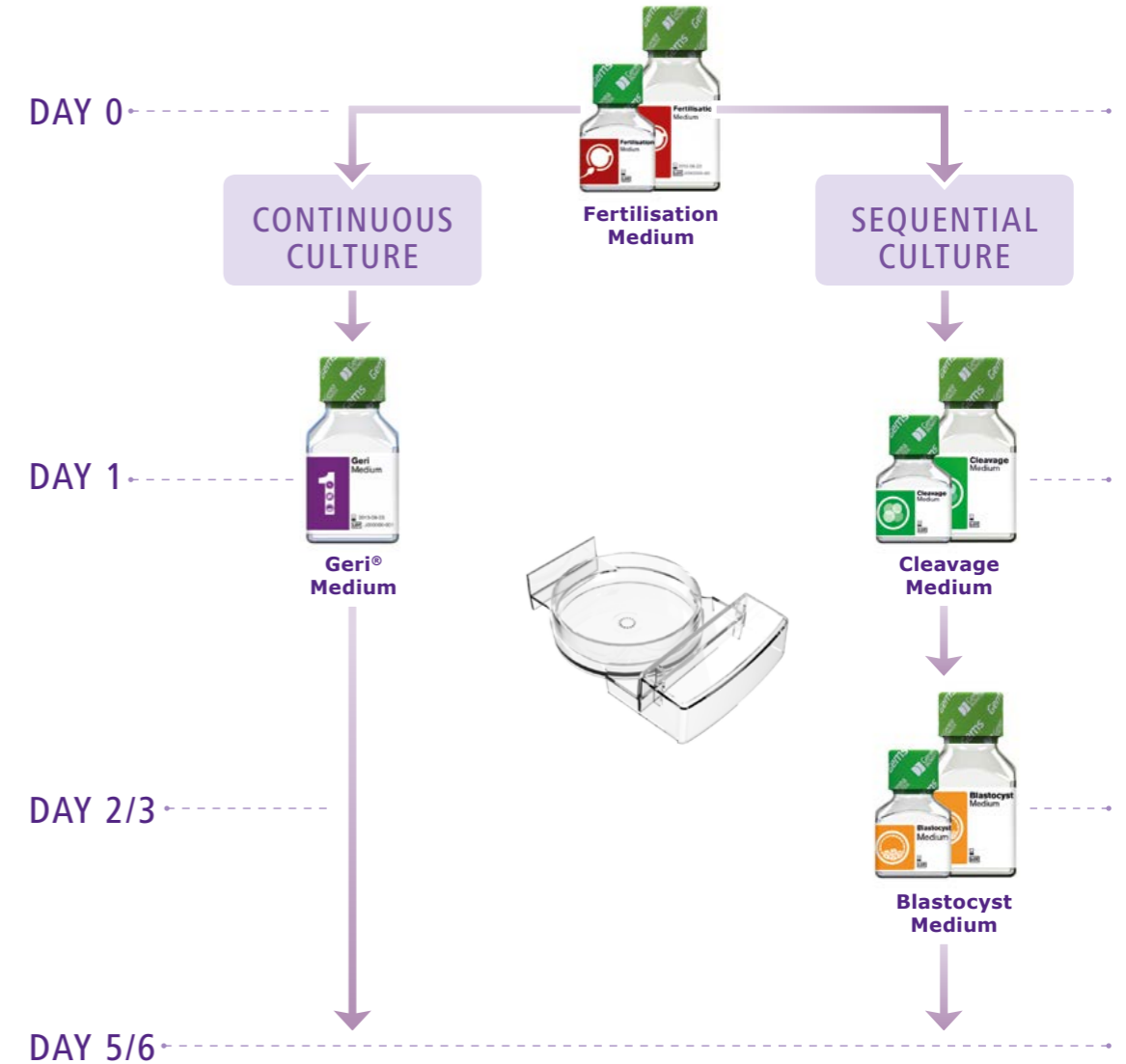

1. Gruber I, Klein M. Embryo culture media for human IVF: which possibilities exist? Journal of the Turkish German Gynecological Association. 2011;12(2):110-117. doi:10.5152/jtgga.2011.25.  
2. QFRM40 Gems® Instructions for Use Rev14.  
3. QFRM907 Fertilisation Medium FEM-50 and FEM-20 tech specs.  
4. QFRM908 Cleavage Medium CLM-50 and CLM-20 tech specs.  
5. QFRM909 Blastocyst Medium BLM-50 and BLM-20 tech specs.  
6. QRTV263 Geri® Medium Study Report.  
7. QFRM902 Gems® Technical Specification Geri® Medium.  
8. Hashimoto S. et al. "Medium without ammonium accumulation supports the developmental competence of human embryos." Journal of Reproduction and Development 54.5 (2008): 370-374.

# CONSTITUENTS & DISTINGUISHING COMPONENTS



GemS® media has key components to support growth and maintain a constant environment especially osmolality and pH.

GemS® media include **gentamicin** — for microbial protection, and a **sodium bicarbonate buffer**. With the exception of the Oocyte Retrieval Buffer, all GemS® media include **human serum albumin (HSA)** — which is used as a protein source.

There are many benefits to HSA for culture media<sup>1</sup>:

- ✓ Aiding embryo metabolism
- ✓ Protecting against toxins
- ✓ Assisting in pH buffering
- ✓ Acting as a colloid osmotic regulator
- ✓ Preventing embryos and gametes sticking to the device used to handle and culture them.

GemS® provides a **robust culture media** including key antioxidants to support embryo development\*:

- **L-carnitine:** An antioxidant that protects DNA and cell membranes from free radical damage<sup>2</sup> and from apoptosis<sup>3</sup>.  
L-carnitine supplementation has also been shown to have a positive effect in cryosurvival rates in bovine and porcine embryos.<sup>4-6</sup>  
**L-carnitine supplementation has been recently correlated with higher number of good quality embryos and improved clinical outcomes in human embryos.**<sup>7</sup>
- **Folic acid (vitamin B<sub>9</sub>):** An antioxidant that supports cell cleavage and growth.<sup>9,10</sup> It is required for synthesis, repair and protection of DNA during methylation.<sup>8,9</sup>
- **Cobalamin (vitamin B<sub>12</sub>):** Supports folic acid during DNA methylation<sup>10</sup> for the methionine synthase function.
- **Ascorbic acid (vitamin C):** An antioxidant that protects DNA and cell membranes from oxidative damage and apoptosis.<sup>11,12</sup> It also reduces DNA fragmentation and abnormal gene expression.<sup>12</sup>

1. QFRM190 GemS® Clinical Evaluation Report.  
 2. Abdelrazik H. et al. "L-carnitine decreases DNA damage and Sperm Medium and Sperm wash Gradients not available in US improves the in vitro blastocyst development rate in mouse embryos." Fertility and sterility 91.2 (2009): 589-596.  
 3. Mansour G. et al. "L-carnitine supplementation reduces oocyte cytoskeleton damage and embryo apoptosis induced by incubation in peritoneal fluid from patients with endometriosis." Fertility and sterility 91.5 (2009): 2079-2086.  
 4. Lowe J.L. et al. "Supplementation of culture medium with L-carnitine improves the development and cryotolerance of in vitro-produced porcine embryos." Reproduction, Fertility and Development 29.12 (2017): 2357-2366.  
 5. Takahashi T. et al. "Supplementation of culture medium with L-carnitine improves development and cryotolerance of bovine embryos produced in vitro." Reproduction, Fertility and Development 25.4 (2013): 589-599.  
 6. Held-Hoelker E. et al. "Cryosurvival of in vitro produced bovine embryos supplemented with L-Carnitine and concurrent reduction of fatty acids." Theriogenology 96 (2017): 145-152.

7. Kim M.K. et al. "Effects and pregnancy outcomes of L-carnitine supplementation in culture media for human embryo development from in vitro fertilization." Journal of Obstetrics and Gynaecology Research 44.11 (2018): 2059-2066.  
 8. O'Neill C. "Endogenous folic acid is essential for normal development of preimplantation embryos." Human Reproduction 13.5 (1998): 1312-1316.  
 9. Antony AC. "In utero physiology: role of folic acid in nutrient delivery and fetal development." The American journal of clinical nutrition 85.2 (2007): 598S-603S.  
 10. Crider KS. et al. "Folate and DNA methylation: a review of molecular mechanisms and the evidence for folate's role." Advances in Nutrition: An International Review Journal 3.1 (2012): 21-38.  
 11. Wang X. et al. "Vitamin C and Vitamin E supplementation reduce oxidative stress-induced embryo toxicity and improve the blastocyst development rate." Fertility and sterility 78.6 (2002): 1272-1277.  
 12. Mortimer D. et al. "Essential features in media development for spermatozoa, oocytes and embryos. Culture Media, Solutions and Systems in Human ART Ed Quinn, P: 47-67.  
 \* Compared to non-supplemented media.

# THE PROOF IS IN THE RESULTS

Gems® media have been in clinical use in Genea ART clinics since March 2013 across all types of IVF/ICSI patients for all ages, helping over an estimated 6500 babies to be born.<sup>1</sup>

## MAXIMISE THE POTENTIAL OF UNDISTURBED INCUBATION

After the implementation of a fully undisturbed culture system in all Genea labs, the Geri® incubator alongside the Geri® Medium provided more supportive environmental conditions for embryos, resulting in an increase in blastocyst quality and embryo utilisation.<sup>1</sup>

GENEA CLINICAL RESULTS BLASTOCYSTS QUALITY AND UTILISATION RATES<sup>1</sup>  
(All clinics, all cycles, combined ages)

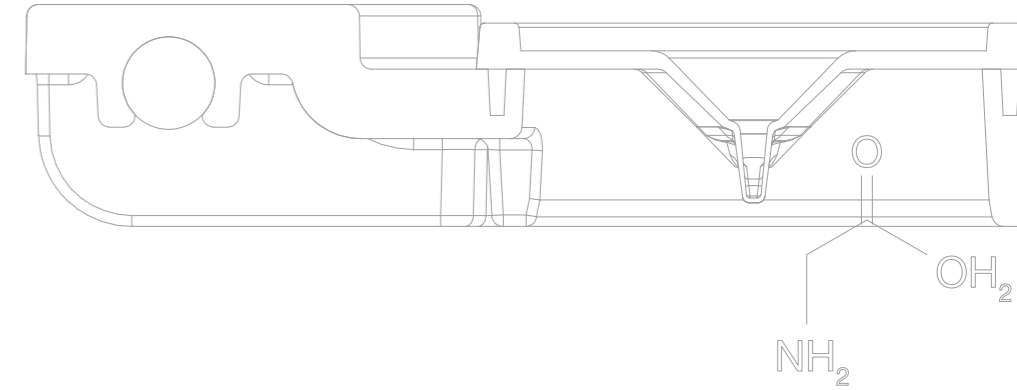
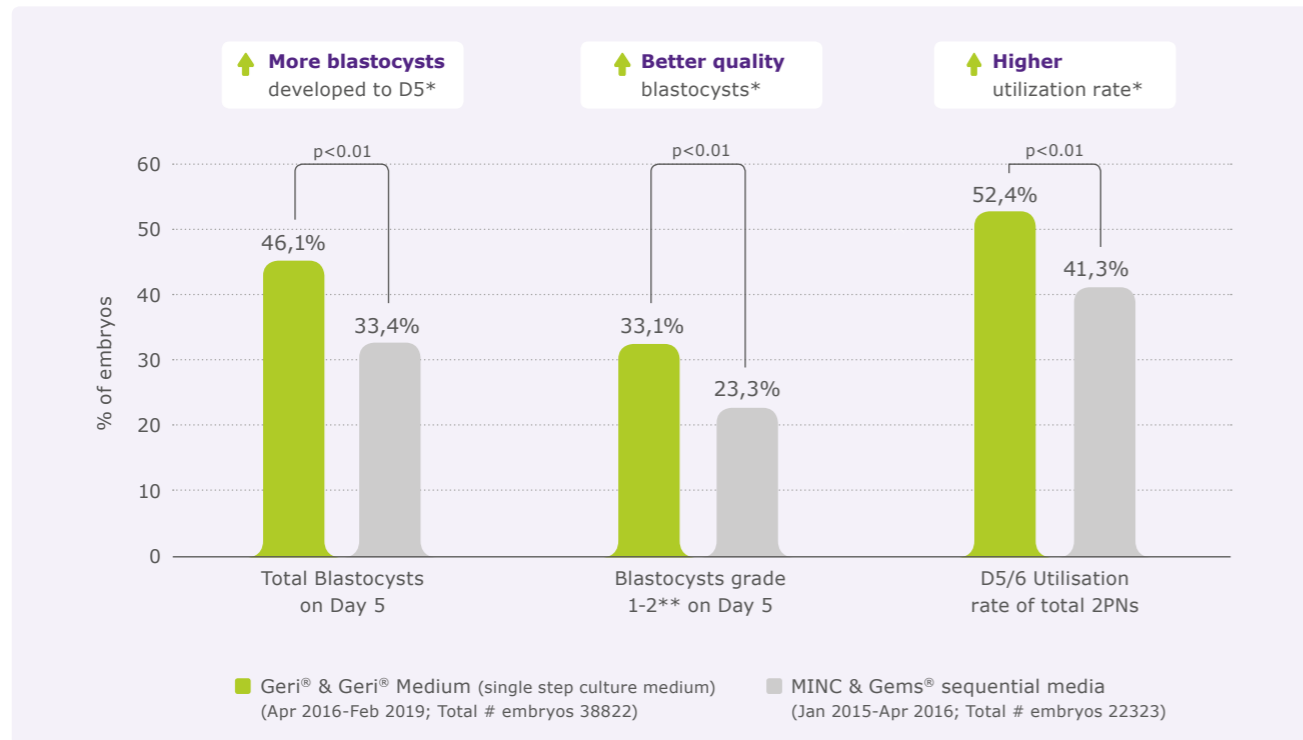

A statistically significant increase ( $p<0.05$ ) in foetal heart pregnancy rate can be seen when Geri® & Geri® Medium are used, compared to when the conventional culture system and sequential media were used. This shows that not only embryo development is improved by the optimised micro-environment of uninterrupted culture, but the practice translates to better clinical outcomes.<sup>1</sup>

GENEA CLINICAL RESULTS AT CANBERRA ART CLINIC.  
FRESH ART CYCLES<sup>1</sup> (Combined ages)

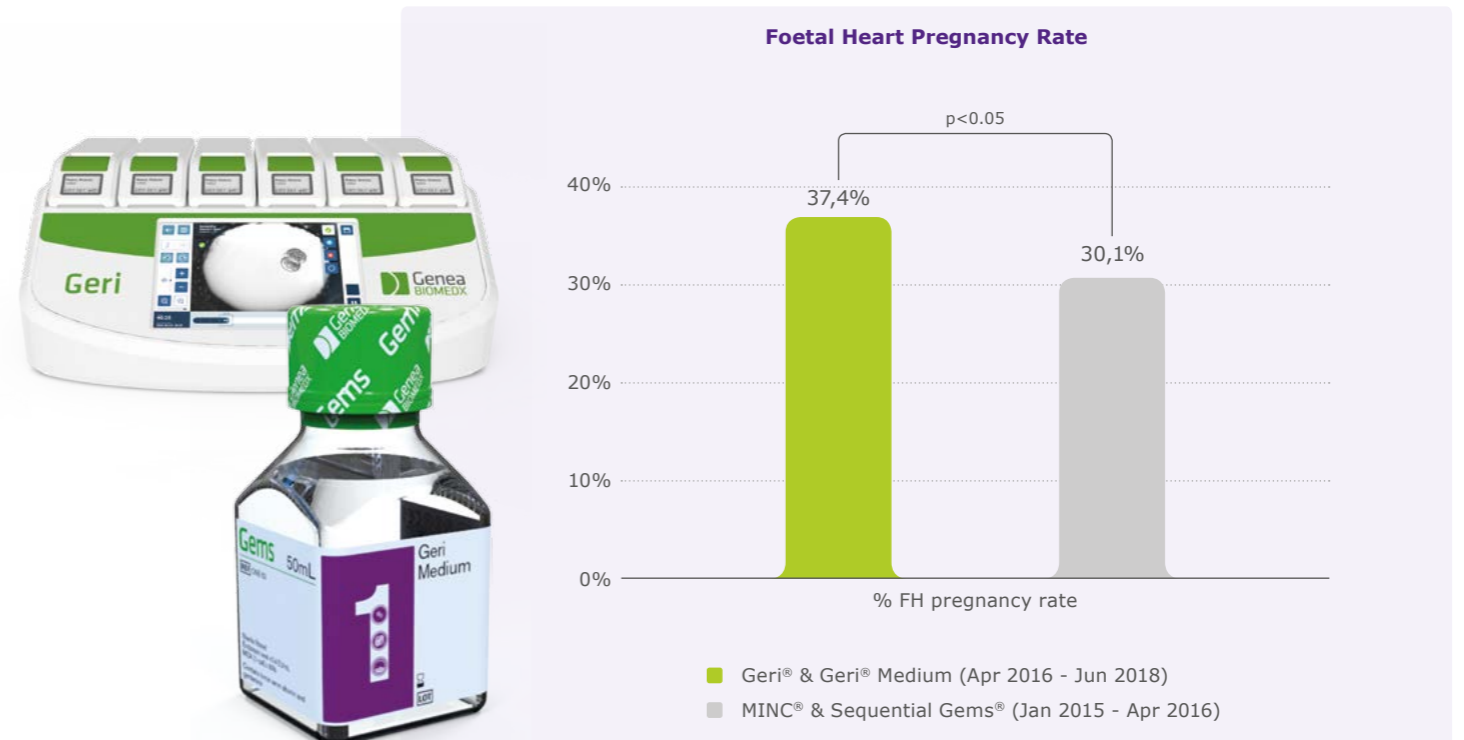

1. Data on file QRTV318\_Human Embryo Culture in Geri®. Embryos which were transferred or frozen prior to day 5 are excluded from the total 2PN count for the purposes of calculating total blastocysts and grade 1/2 blastocysts because their potential fate is unknown.  
\* Statistically significant differences ( $p<0.01$ ).  
\*\* Genea grading.

# EASE OF USE

**Pre-supplemented with human serum albumin (HSA)\*** as protein source<sup>1,2</sup>, Gems® supports a standardized practice backed by thorough quality testing.

- **Ready-to-use** solutions to aid standardization.
- **CE Mark and FDA approval\*\*** across the entire product range.
- Clear labelling aids recognition and **minimizes the potential for errors.**<sup>3</sup>

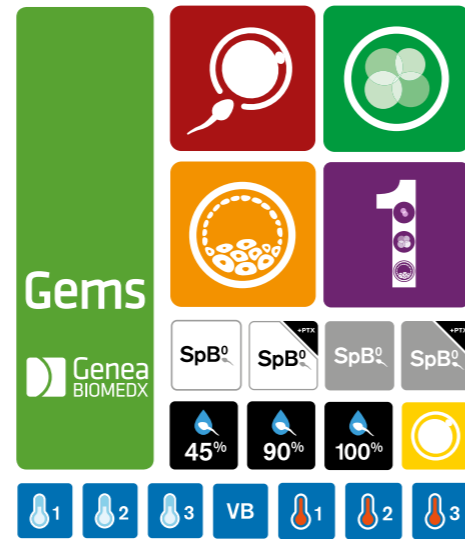
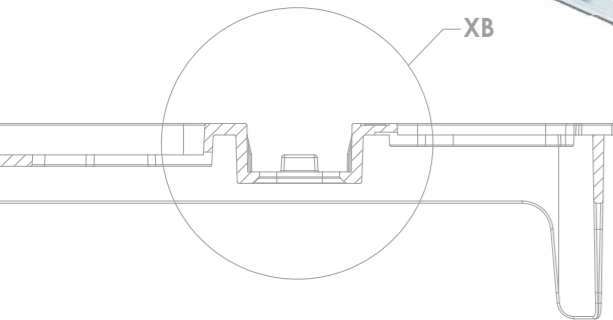
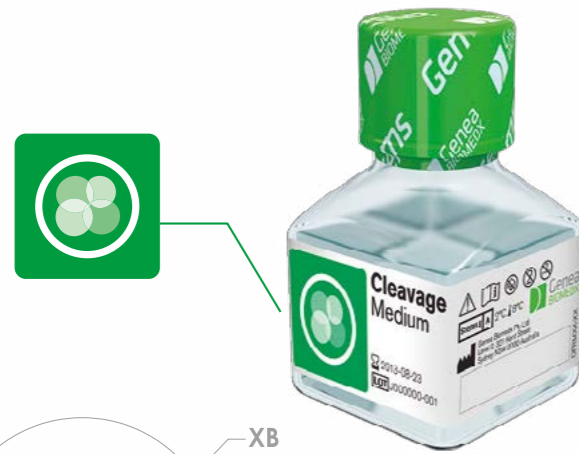

# EXTENSIVE QUALITY CONTROL<sup>1</sup>

All media tested for the following:

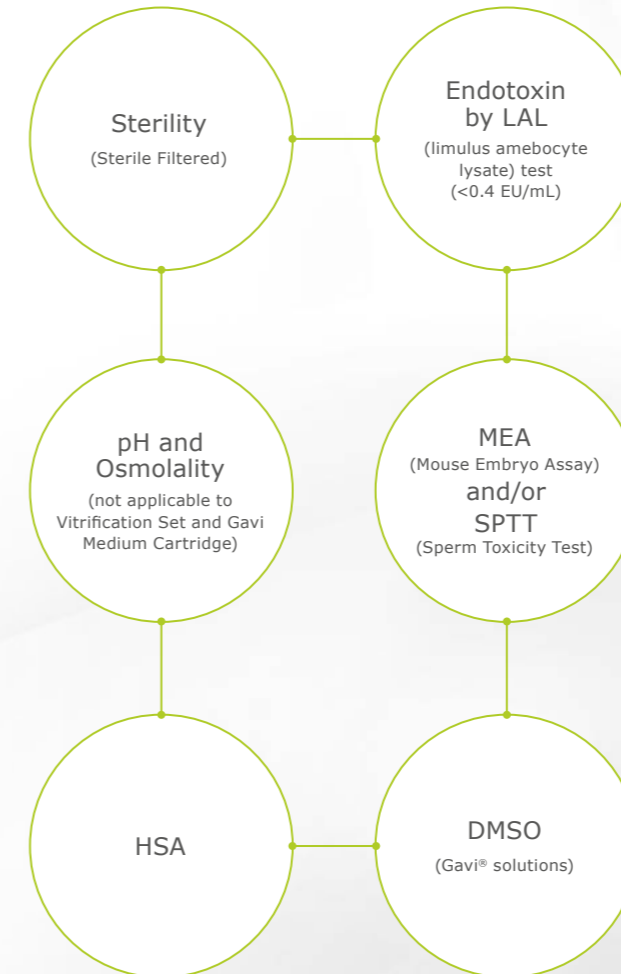

1. QFRM40 Gems® instructions for use.  
 2. Laverge H. et al. "Prospective randomized study comparing human serum albumin with fetal cord serum as protein supplement in culture medium for in-vitro fertilization." Human reproduction (Oxford, England) 12.10 (1997):2263-2266.  
 3. Human Fertilisation and Embryology Authority (HFEA). Adverse incidents in fertility clinics: lessons to learn 2010–2012. Available at <http://www.hfea.gov.uk/9449.html>. Accessed January 2017. Last updated September 2015.  
 \* With the exception of the Oocyte Retrieval Buffer and Vit Solution 3 of the vitrification set VIT-01.  
 \*\* Sperm media pending FDA clearance.



For healthcare professionals only. As part of Merck's policy of continuous development, we reserve the right to change product specifications without prior notification.

Please refer to the instructions for use.

Gems® complies with the current legislation of medical devices. The Gems® solutions are CE marked and have received the FDA approval, (FDA clearance pending for Sperm Media only).

Manufactured by Planet Innovation.  
Distributed by Merck KGaA, Darmstadt, Germany.

For further information, please contact your Merck representative or visit:

**[www.fertility.com](http://www.fertility.com)**

1. Data on file at Genea ART clinics QRTV318\_Human Embryo Culture in Geri®. Audited birth outcome results from internally reported Laboratory Performance Measures (LPMs).
2. QFRM190 Gems® Clinical Evaluation Report.
3. Mortimer D. "Human blastocyst development media." Human Reproduction 16.12 (2001): 2725.

